



Filtration unit OF7

Description

The filter unit OF7 is used as a portable service unit for filling hydraulic plants, flushing small hydraulic plants and dedusting in bypass flow.

Optionally, the OF7 can be ordered with the ContaminationSensor CS 1000. This allows the solid particle contamination to be monitored at the same time. The cleanliness results are displayed according to ISO, SAE and NAS classifications.

Applications

- Filtered and unfiltered filling of hydraulic systems
- Temporary offline filtration of hydraulic systems
- Filtered and unfiltered fluid transfer

Advantages

- Improvement in service life for components and system filters
- Increased oil service life
- Greater machine availability
- Simple operation
- Compact construction
- Option: continuous monitoring of oil cleanliness during the cleaning process through the use of CS 1000 (OF7CM)
- Optional: integral dry-running protection and control line for remote maintenance (OF7K)
- Optional: version for viscosities up to 1000 mm²/s and spin-on cartridges in size 180 (OF7S90Px)

Technical data

Max. flow rate	OF7S	15 l/min
	OF7K/OF7CM	10 l/min
Pump type	Vane pump	
Operating pressure	3.5 bar max.	
Permitted suction pressure at suction port	-0.4 bar to +0.6 bar	
Viscosity range	OF7S10/OF7K10:	5 to 350 mm ² /s
	OF7CM:	5 to 200 mm ² /s
	OF7S90Px:	15 to 1000 mm ² /s
Permitted operating fluid	Mineral oil (DIN 51424)	
Fluid temperature	0 to 80°C	
Ambient temperature	-20 to 40°C	
Seals	NBR	
Protection class	IP 54	
Length of power cable	2.8 m	
Length of hoses	2.5 m	
Hoses	Suction hose NW 20 with lance	
	Pressure hose NW 16 with lance	
Weight	OF7S10/OF7K10 ≈ 12.5 kg (empty)	
	OF7S90Px/OF7CM ≈ 18.0 kg (empty)	

Recommended standard models

Filter aggregate	Part no.
OF7S10P1M1B03E	92164
OF7S10P1M1 ... E	92160 *
OF7S10P1M1B05E	92161
OF7S10P1M1B10E	92162
OF7S10P1M1P10E	92165
OF7S10P1M1B20E	92163
OF7S10P1M1LE	3147177
OF7CM10P2M1 ... E/-C1	3504991

* Please order elements (spin-on cartridges) separately

Replacement elements (spin-on cartridges)

Element size	Filtration rating	Element type	Part no.
160	3 µm	0160 MA 003 BN	314609
160	5 µm	0160 MA 005 BN	315621
160	10 µm	0160 MA 010 BN	314022
160	20 µm	0160 MA 020 BN	315485
160	10 µm	0160 MG 010 P	249005
-		Empty cartridge	300082
180	3 µm	0180 MA 003 BN	310475
180	5 µm	0180 MA 005 BN	315622
180	10 µm	0180 MA 010 BN	315726
180	20 µm	0180 MA 020 BN	315623
180	10 µm	0180 MA 010 P	308122

Model code

OF7 S 10 P 1 M 1 B 10 E /-C1

Basic type

OF7

Model

- S = Standard
- K = Special version with dry-running protection (e.g. for leakage oil extraction)
- CM = Fluid Condition Monitoring

Typen code

- 10 = Standard
- 90⁽¹⁾ = Special design with increased power (370 W) and filter capacity (180 spin-on cartridge)

Seals

- P = NBR (Perbunan)

Pump type

Meas. ref.	Flow rate	max. Viscosity
1 ⁽¹⁾	15 l/min	350 mm ² /s
2	10 l/min	200 mm ² /s
X ⁽¹⁾ other flow rates on request		

Drive motor

- D⁽¹⁾ = compressed-air motor
- K = 1x 110 V 50 Hz, 0.18 kW or 115 V 50 Hz, 0.18 kW or 115 V 60 Hz, 0.18 kW
- M = 1x 230 V 50 Hz, 0.18 kW (**Standard**)
- N^{* (1)} = 3x 380-420 V 50 Hz, 3x 440-480 V (60 Hz)
- T = 12 V DC, 0.2 kW
- U = 24 V DC, 0.2 kW
- X⁽¹⁾ = other voltages on request
- * without on/off switch, cable and plug

Filter size

- 1 = element 160 (spin-on cartridge)
- 2⁽¹⁾ = element 180 (spin-on cartridge)

Filter material

- B = Betamicon® (BN)
- L = empty filter element for unfiltered recirculation
- P = paper (P)

Filtration rating

- 03 = 3 µm BN
- 05 = 5 µm BN
- 10 = 10 µm BN, P
- 20 = 20 µm BN

Clogging indicator

- E = back-pressure indicator (no other options available!)

Supplementary details for version OF7CM

- C1 = ContaminationSensor CS1320

⁽¹⁾ not available for version OF7K or OF7CM

Dimensions

OF7S10 / OF7K10

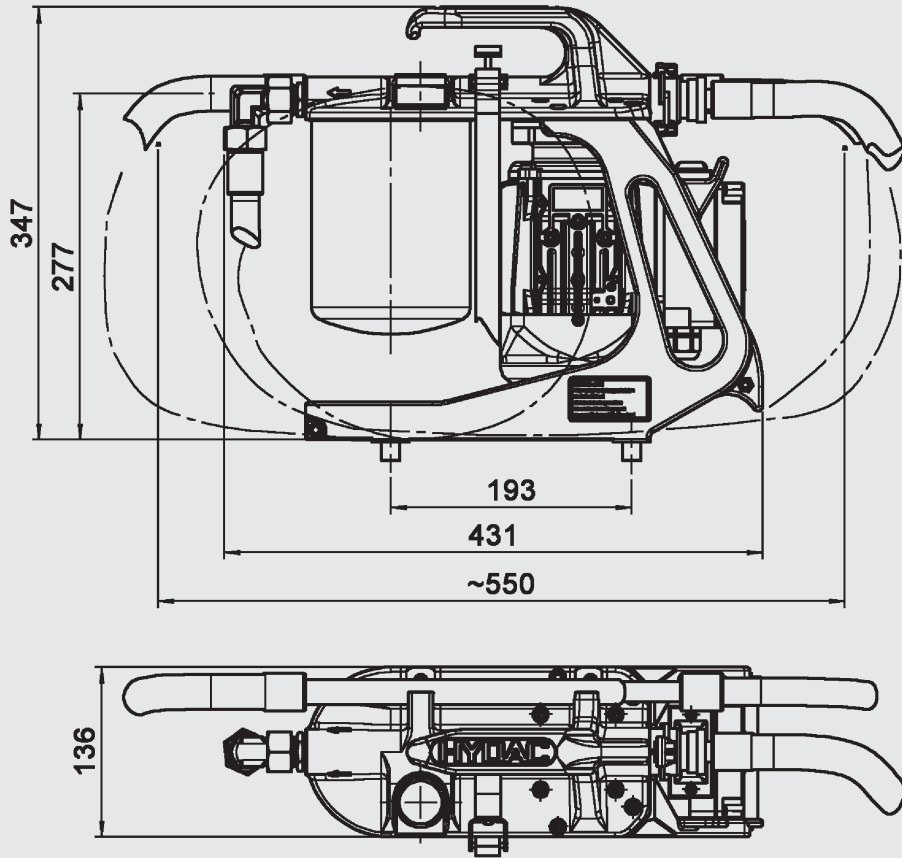

Hydraulic circuit

OF7S

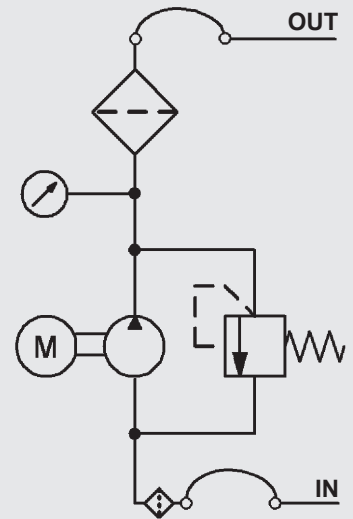

OF7K

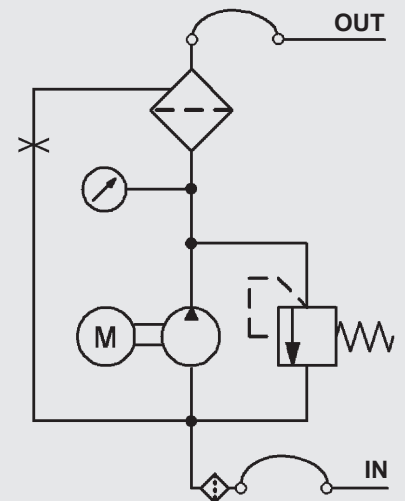

Dimensions

OF7CM10

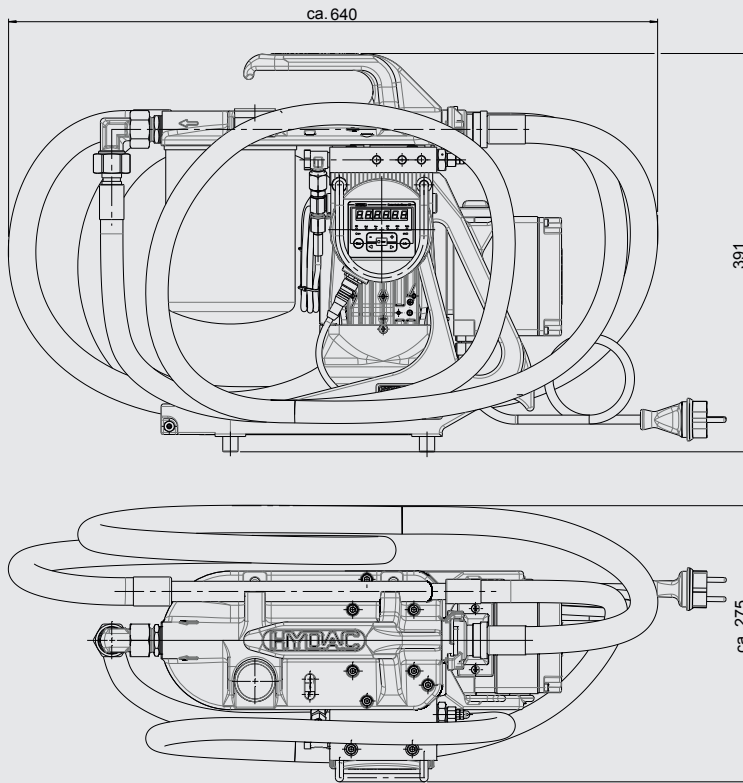

Dimensions

OF7S90

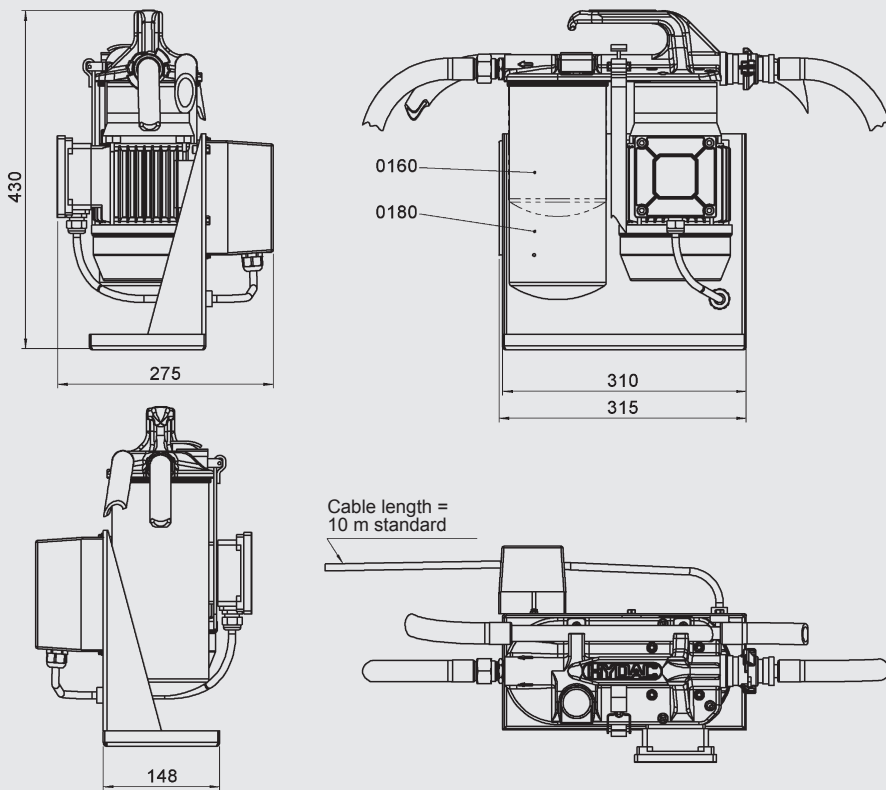

Note

The information in this brochure relates to the operating conditions and applications described.

For applications and operating conditions not described, please contact the relevant technical department.

Subject to technical modifications.

Hydraulic circuit

OF7CM

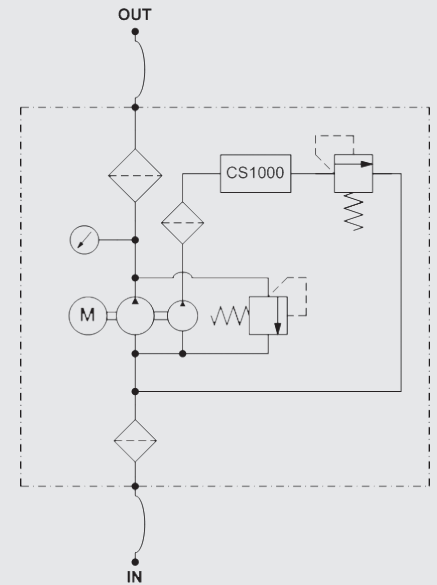

Hydraulic circuit

OF7S90

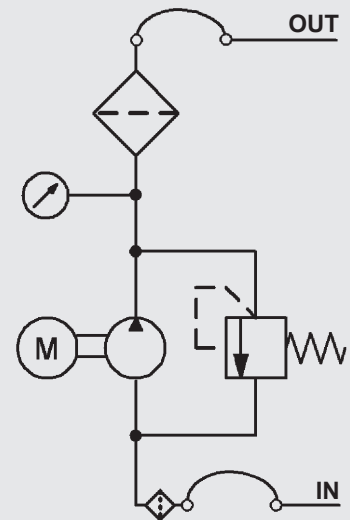

HYDAC FILTER SYSTEMS GMBH

Industriegebiet

D-66280 Sulzbach / Saar, Germany

Tel.: +49 (0) 6897/509-01

Fax: +49 (0) 6897/509-9046

Internet: www.hydac.com

E-mail: filtersystems@hydac.com